

4/23/16

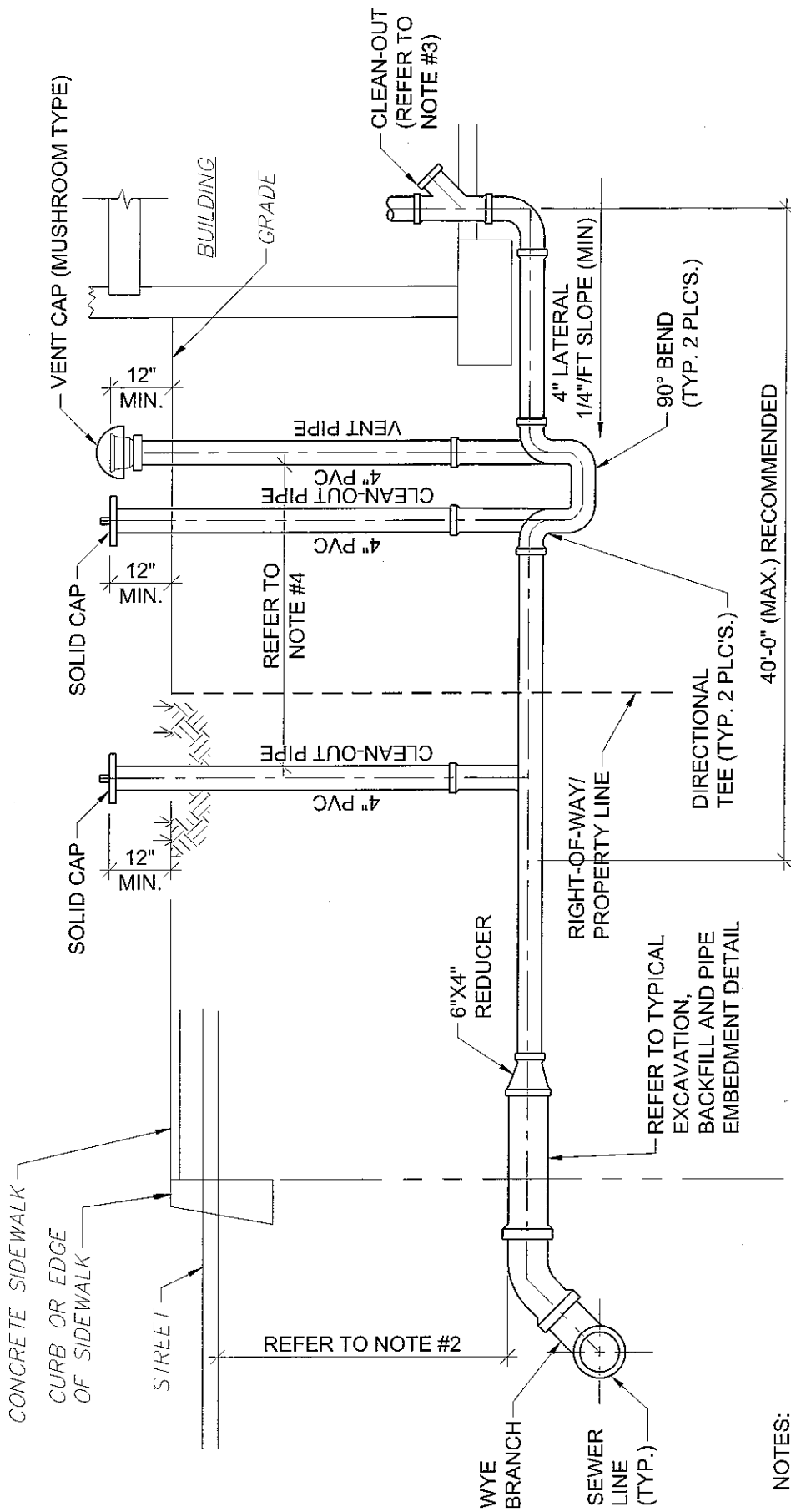

NOTES:

1. ~~DOUBLE~~ **SINGLE** RUNNING TRAP WILL BE INSTALLED WITHIN ONE PIPE LENGTH OF THE END OF THE 6" LATERAL.
2. MINIMUM DEPTH OF 4" LATERAL WILL BE 48" BELOW FINISHED GRADE UNLESS APPROVED BY ENGINEER.
3. IF THERE IS NOT A CLEANOUT LOCATED INSIDE OF DWELLING AN ADDITIONAL CLEANOUT SHALL BE INSTALLED IMMEDIATELY OUTSIDE OF THE BUILDING PRIOR TO RUNNING TRAP
4. LOCATE VENT CAP AND CLEANOUT IN LAWN AREA. MUSHROOM CAP SHALL BE USED ON VENT. *CLEAN OUT SHOULD BE NO MORE THAN 46" A PART*
5. ~~IN GENERAL, SANITARY SEWERS SHOULD BE LOCATED AT LEAST 100 FEET FROM PUBLIC WATER SUPPLY SOURCES AND 50 FEET FROM PRIVATE WATER SUPPLY SOURCES, UNLESS THE SANITARY LINES ARE ENCASED IN CONCRETE OR APPROVED EQUIVALENT.~~
6. REFER TO DRAWING S-17 FOR LATERAL NOTES.
7. EXISTING UNDERGROUND PIPING TO BE REPLACED.

TYPICAL HOUSE CONNECTION

SCALE: NONE
 CONNECTION SHOULD BE MADE NO MORE THAN 2 FEET FROM STRUCTURE TO OLD SYSTEM

ENTECH ENGINEERING
 1.800.825.1403
 www.entecheng.com
 Reading (Corporate Office)
 4 South Fourth Street | P.O. Box 32 | Reading, PA 19603-0032
 p: 610 375 0587 | f: 610 375 7537
 Pottsville p: 610 623 5685 | Mountaintop p: 610 688 0275 | Lititz p: 717 528 6809 | Pittsburgh p: 412 206 2630

WEST COCALICO TOWNSHIP AUTHORITY
 PO BOX 95, 156B W. MAIN STREET REINHOLDS, PA 17569
INFRASTRUCTURE
 TYPICAL HOUSE CONNECTION

DATE:	07/10/2023	SCALE:	AS NOTED
PREPARED BY:	MAH	PROJECT NO.	4137.49
CHECKED BY:	CTT	DRAWING NO.	S-16
APPROVED BY:	HAE		

LATERAL NOTES:

1. 1. ALL MATERIAL USED FOR HOUSE SANITARY SEWER INSTALLATIONS SHALL BE NEW, FREE FROM DEFECTS AND CONFORM TO ALL STANDARDS SET FORTH BY WEST COCALICO TOWNSHIP AUTHORITY OR LOCAL CODES.
2. ALL BUILDING LATERALS MUST BE INSPECTED AND APPROVED BEFORE BACKFILLING THE CONTRACTOR SHALL NOTIFY THE AUTHORITY A MINIMUM OF 24 HOURS PRIOR TO RECEIVING A FINAL INSPECTION. DATE AND TIME OF FINAL INSPECTION IS SUBJECT TO THE AVAILABILITY OF AN INSPECTOR.
3. ADJACENT HOMES MAY EACH BE SERVED BY LATERALS IN A COMMON TRENCH. IN THIS EVENT, THE LATERALS SHALL BE SEPARATED BY 4" MIN CLEARANCE. OTHER BEDDING AND TRENCH DIMENSIONS WILL BE AS SHOWN ON DRAWING S-15.
4. BUILDING LATERALS SHALL BE TESTED IN ACCORDANCE WITH SECTION 02731

MATERIAL ALLOWED BY WEST COCALICO TOWNSHIP AUTHORITY FOR HOUSE SANITARY SEWERS

1. PVC BELL AND SPIGOT SEWER PIPE / SDR 35.
2. CAST IRON SOIL PIPE AND FITTINGS ASTM #A74-66 SERVICE OR EXTRA HEAVY ONLY.
3. PVC SEWER PIPE SCH 40 AND FITTINGS / ** ASTM #D2265-68.
4. SLIP-SEAL GASKETS FOR CAST IRON BELL AND SPIGOT PIPE / ASTM #D1869 OR 4. LEAD AND OAKUM.
5. MINIMUM DIAMETER 4 INCH.

** - ALL SCHEDULE 40 PIPE AND FITTINGS OF PVC FORMULATION REQUIRE APPROPRIATE HIGH ETCHING COLOR SOLVENT PRIMER PLUS THE SOLVENT CEMENT FOR MAKING JOINTS. IF THE PRIMER IS OMITTED, THE WORK WILL BE REJECTED.

 <p>1.800.635.4463 www.entecheng.com</p> <p>Reading (Corporate Office) 4 South Fourth Street P.O. Box 322 Reading, PA 19603-0322 p: 610.373.6897 f: 610.373.7597</p> <p>Pottsville Mount Airy Luzerne Philadelphia p: 610.828.5656 p: 610.995.0275 p: 717.822.9699 p: 412.284.2800</p>	WEST COCALICO TOWNSHIP AUTHORITY PO BOX 95, 156B W. MAIN STREET REINHOLDS, PA 17569		DATE: 03/11/14	SCALE: AS NOTED
	INFRASTRUCTURE LATERAL NOTES		PREPARED BY: MAH	PROJECT NO. 4137.49
			CHECKED BY: CTI	DRAWING NO. S-17
			APPROVED BY: HAE	

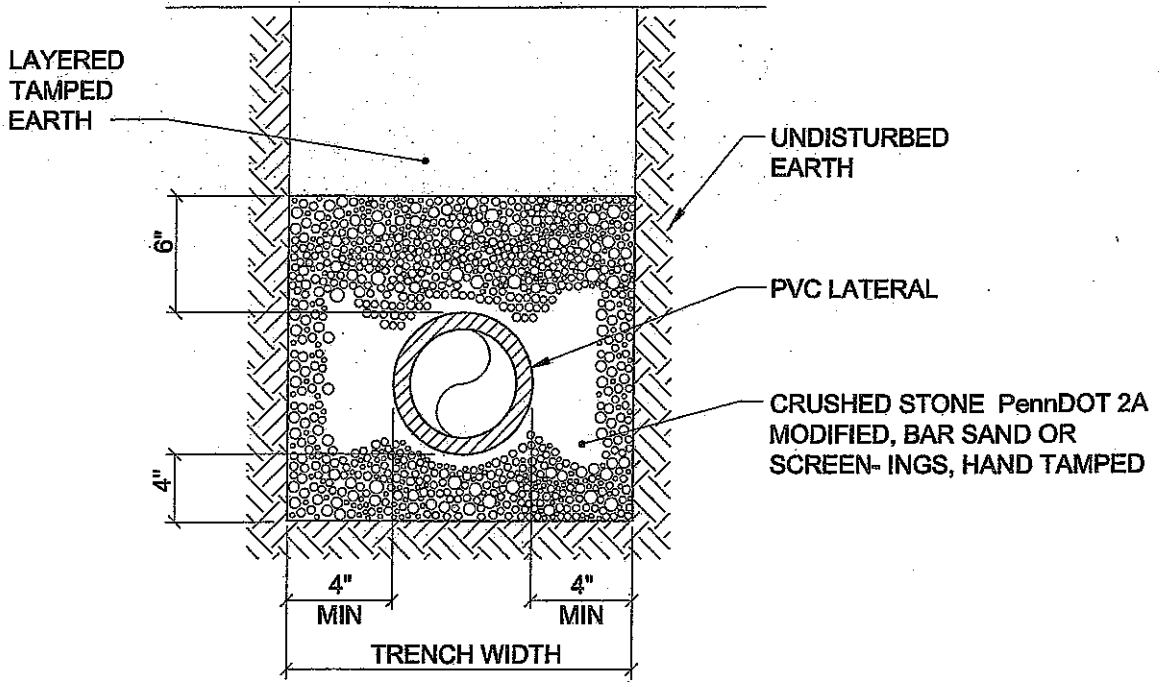
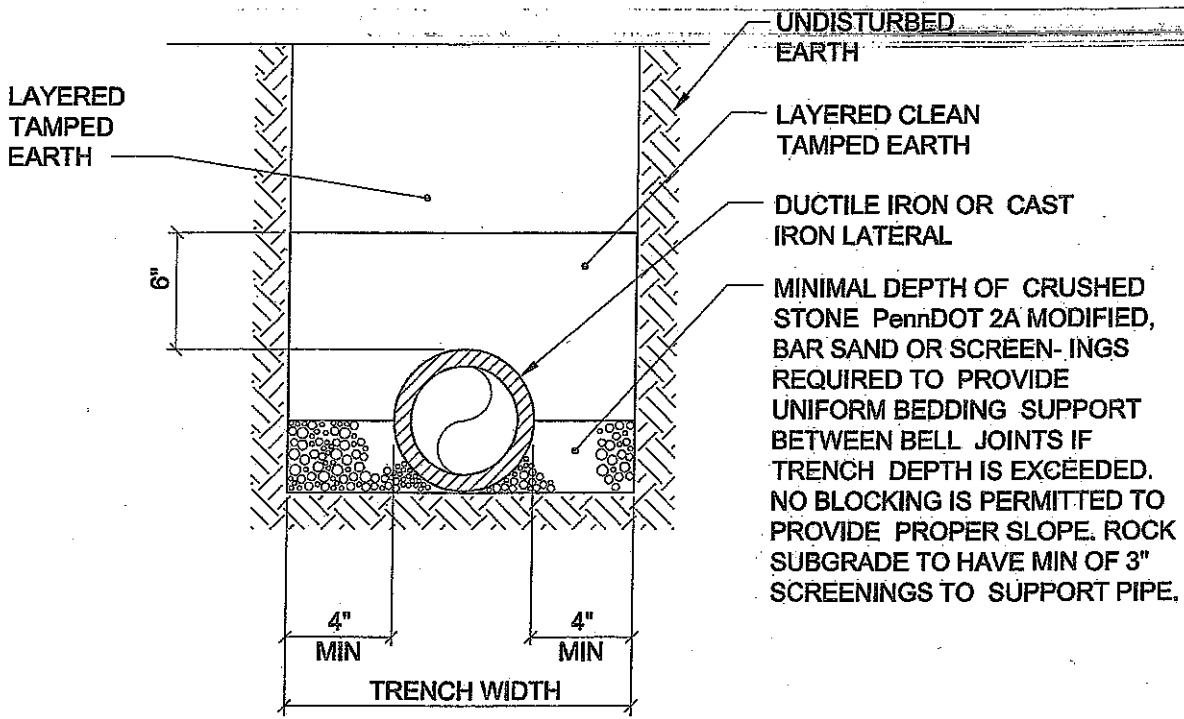

NOTE: CRUSHED STONE PennDOT 2A MODIFIED, BAR SAND OR SCREENINGS BEDDING TO BE THOROUGHLY COMPACTED PRIOR TO PIPE PLACEMENT.

TYPICAL LATERAL TRENCH

SCALE: NONE

ENTECH ENGINEERING
 1.800.825.1403
 www.entechny.com

Reading (Corporate Office)
 4 South Fourth Street | P.O. Box 32 | Reading, PA 19603-0032
 P: 610.373.6587 | F: 610.373.7537

Pottsville
 22 87th Street, Suite 100
 P: 610.373.6587 | F: 610.373.7537

Lebanon
 1822
 P: 717.662.9569 | F: 717.662.9569

Philly
 2642
 P: 412.294.2809

WEST COCALICO TOWNSHIP AUTHORITY
 PO BOX 95, 156B W. MAIN STREET REINHOLDS, PA 17569

INFRASTRUCTURE
 TYPICAL LATERAL TRENCH

DATE: 08/11/14	SCALE: AS NOTED
PREPARED BY: MAH	PROJECT NO. 4137.49
CHECKED BY: CTT	DRAWING NO. S-14
APPROVED BY: HAE	

General

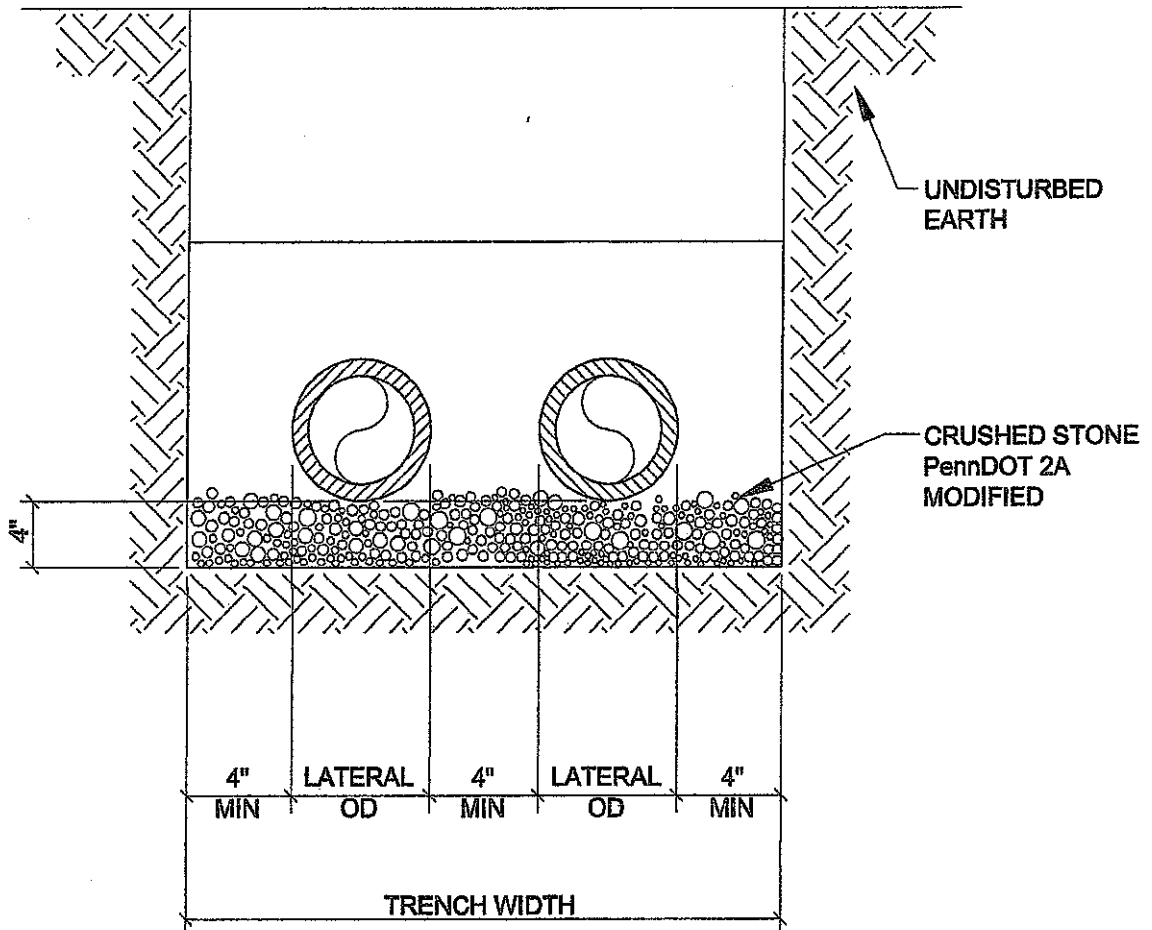

TYPICAL DOUBLE LATERAL TRENCH

SCALE: NONE



Reading (Corporate Office)
4 South Fourth Street | PO Box 321 | Reading, PA 19603-0321
P: 610.372.5287 | F: 610.372.7537

Pottsville
P: 610.281.2444

Lehigh Valley
P: 717.262.6666

Phoenix
P: 480.564.2200

WEST COCALICO TOWNSHIP AUTHORITY
PO BOX 95, 156B W. MAIN STREET REINHOLDS, PA 17569

INFRASTRUCTURE

TYPICAL DOUBLE LATERAL TRENCH

DATE: 08/11/14	SCALE: AS NOTED
PREPARED BY: MAH	PROJECT NO. 4137.49
CHECKED BY: CTT	DRAWING NO. S-15
APPROVED BY: HAE	

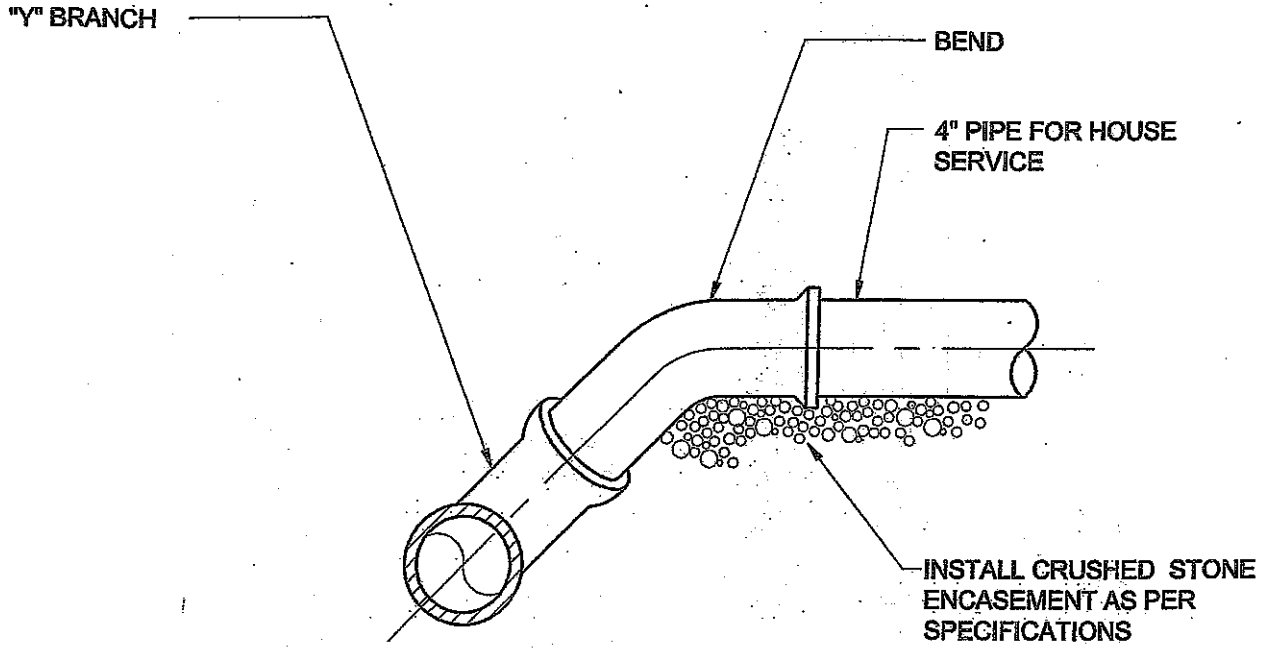

NOTES: THE SIZE OF THE HOUSE SERVICE BEND & "Y" BRANCH SHALL BE 4" IN ACCORDANCE WITH SPECIFICATIONS.

"Y" BRANCH FOR LATERALS

SCALE: NONE



1.800.825.4403
www.entecheng.com

Reading (Corporate Office)
4 South Fourth Street | P.O. Box 321 | Reading, PA 19603-0321
p: 610.274.6507 | f: 610.274.7337

Pottsville | Mechanicsville | Littleton | Philadelphia
p: 610.233.5555 | p: 717.660.0073 | p: 773.207.6500 | p: 482.234.1200

WEST COCALICO TOWNSHIP AUTHORITY
PO BOX 95, 156B W. MAIN STREET REINHOLDS, PA 17569

INFRASTRUCTURE

"Y" BRANCH FOR LATERALS

DATE:
08/11/14

PREPARED BY:
MAH

CHECKED BY:
CTT

APPROVED BY:
HAE

SCALE:
AS NOTED

PROJECT NO.
4137.49

DRAWING NO.

S-18

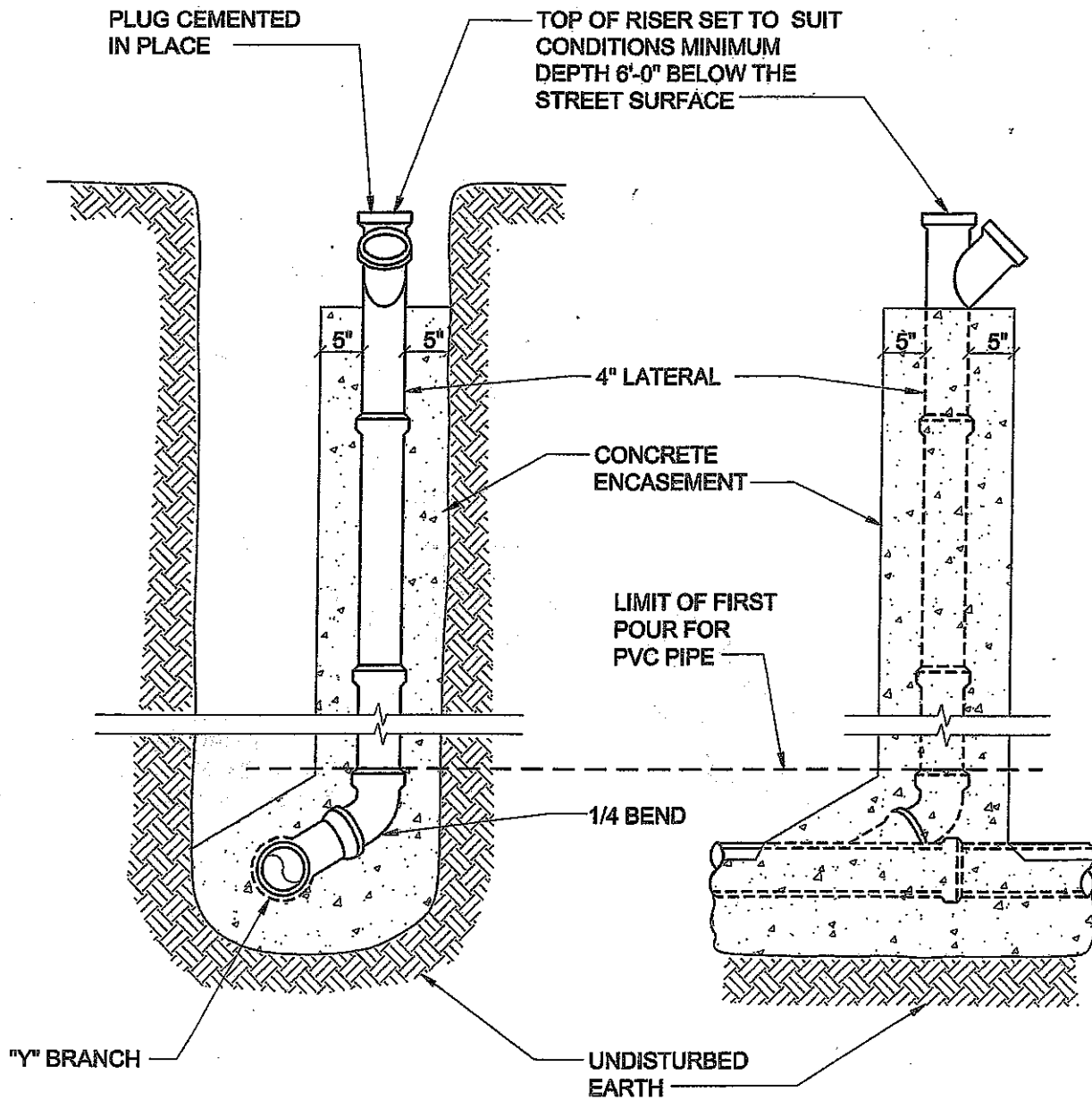

NOTE: ALL CONCRETE SHALL HAVE MINIMUM COMPRESSIVE STRENGTH OF 3000 PSI AT THE END OF 28 DAYS.

DEEP CUT LATERAL

SCALE: NONE

ENTECH
ENGINEERING
1.800.625.4403
www.entechny.com

Reading (Corporate Office)
4 South Fourth Street (P.O. Box 32) Reading, PA 19603-0032
P: 610.372.8227 F: 610.372.2207

Pottsville
P: 610.828.5655
Middletown
P: 610.298.0275
Lifft
P: 717.828.8555
Pittsburgh
P: 412.234.2800

WEST COCALICO TOWNSHIP AUTHORITY
PO BOX 95, 156B W. MAIN STREET REINHOLDS, PA 17569

INFRASTRUCTURE
DEEP CUT LATERAL

DATE: 08/11/14	SCALE: AS NOTED
PREPARED BY: MAH	PROJECT NO. 4137.49
CHECKED BY: CTT	DRAWING NO. S-19
APPROVED BY: HAE	